

1146 46 Ascendant Series Caster Series(All Plastic)



Resolute Rubber wheel (all black) Wheel Diameter x Wheel Width 75 x 14mm

EAN

KS-11460300455273

Adjustable Casters, Threaded Stem M10x25
 Black Casters made of polypropylene reinforced material
 Rust-proof, Corrosion resistant, Attractive appearance, Economical, and allows for smooth rotation
 High-Quality Impact-Resistant Polypropylene Wheel Center, High-Quality Reinforced Polypropylene Rubber (TPR) Wheel Tread
 Black, Bearing—Ball Bearings

Wheel tread: Thermoplastic rubber elastomer (TPR)
 Wheel Center: Made of high-quality impact-resistant polypropylene

Drawings are for reference only and may differ from the product

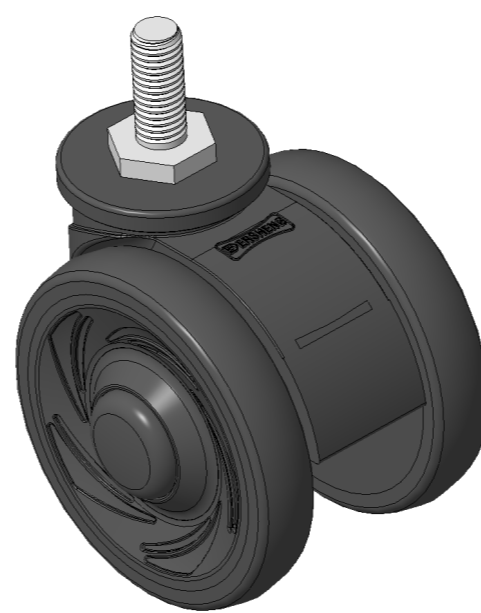

Picture may differ from original product

Technical Data

Metric Imperial

Wheel Diameter	75mm
Wheel Width	60mm
Wheel Bearing	Wheels With Ball Bearings
Threaded Stem	M10
Threaded Length	25mm
Offset	23mm
Swivel Interference	134mm
Overall Height	84mm
Swivel Radius	67mm
Hardness Of Tread	72±5° Shore A
Load Capacity (Dynamic)	90kgs
Load Capacity (Static)	135kgs
Temperature	-20°C to +60°C
Fork Type	Swivel Caster
Stainless	N/A
Electrical Conductivity	N/A
Anti-Static	N/A
Weight	0.26kgs
Standard	ISO22883

Advantages at a glance

Rolling Resistance	•••••
Operating Noise	•••••
Floor Surface Preservation	•••••

Dimensions

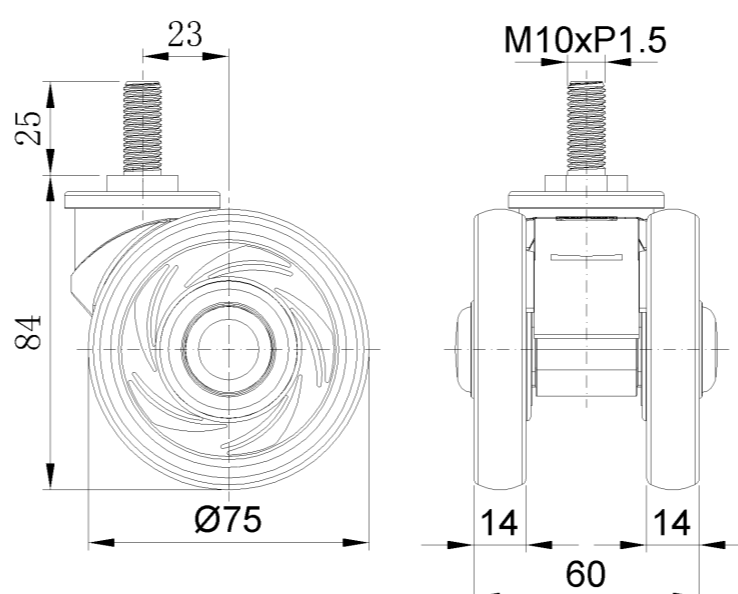

Mounting

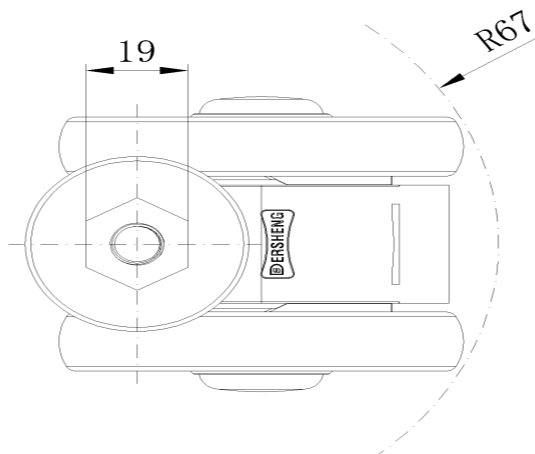

* For any deviation between metric and imperial spec, please refer to the metric spec.