

# 1165-3 AMR/AGV-3 Double Precision Ball Bearing Caster (Medium Duty) Series



AQPU (Grey round) Wheel Diameter × Wheel Width 75 x 30mm

EAN

KS-11650303601013

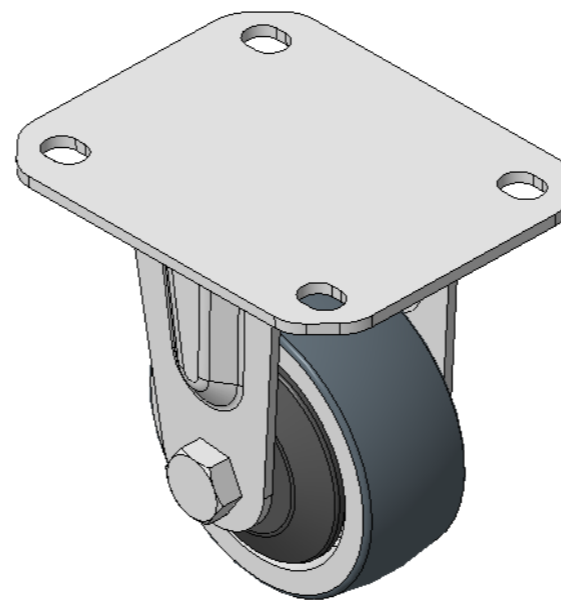

Drawings are for reference only and may differ from the product

Picture may differ from original product

## Technical Data

Imperial  Metric

Wheel Diameter	3 "
Wheel Width	1-3/16 "
Wheel Bearing	Wheels With Ball Bearings
Plate Size	4-3/8 " x 3-7/16 "
Bolt Hole Spacing	3-3/16 " x 2-7/16 "
Plate Hole	1/2 " x 23/64 "
Overall Height	4-3/16 "
Hardness Of Tread	77±5° Shore A
Load Capacity (Dynamic)	331lbs
Load Capacity (Static)	496lbs
Temperature	-4°F to +158°F
Fork Type	Rigid Caster
Stainless	N/A
Electrical Conductivity	N/A
Anti-Static	N/A
Weight	2.3lbs
Standard	ISO22883

## Advantages at a glance

Rolling Resistance	● ● ● ● ●
Operating Noise	● ● ● ● ●
Floor Surface Preservation	● ● ● ● ●

## Dimensions

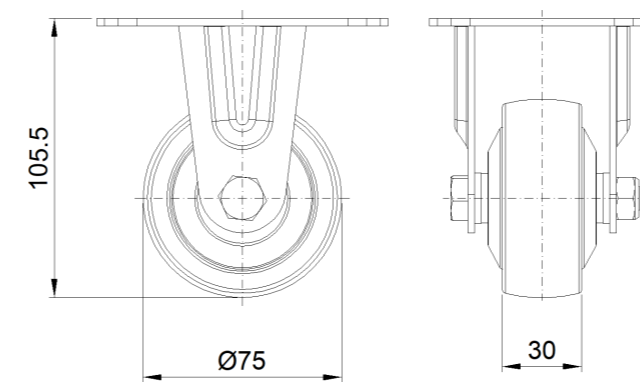

## Mounting

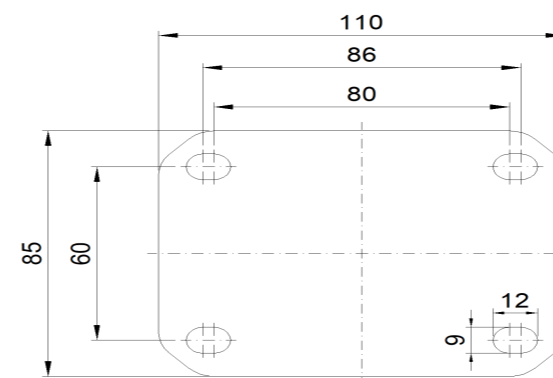

\* For any deviation between metric and imperial spec, please refer to the metric spec.