

1121 Double Raceway, Light Duty Caster Series

PP wheel (black) Wheel diameter x wheel width 125 x 27 mm

EAN

TW-112105002A009

Swivel Casters, mortise-and-tenon Stamping Fork—Ø11x51L Zine-Plated, mortise-and-tenon Mounting Type system with brass buckles Polypropylene Wheel Center and rim Black, Plain Bearings.

Wheel surface: Polypropylene

Wheel Center: Polypropylene

Drawings are for reference only and may differ from the product

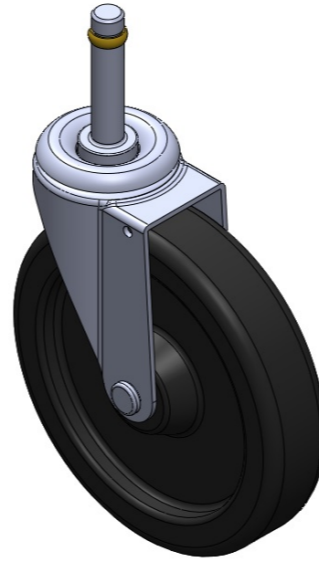

Picture may differ from original product

Technical Data

Imperial Metric

Wheel Diameter	5 "
Wheel Width	1-1/16 "
Wheel Bearing	Wheel With Plain Bearing
Stem Diameter	3/8 "
Stem Length	1-15/16 "
Offset	1-3/16 "
Swivel Interference	7-5/16 "
Overall Height	5-3/4 "
Swivel Radius	3-5/8 "
Hardness Of Tread	65±5° Shore D
Load Capacity (Dynamic)	198lbs
Load Capacity (Static)	298lbs
Temperature	14°F to +140°F
Fork Type	Swivel Caster
Stainless	N/A
Electrical Conductivity	N/A
Anti-Static	N/A
Weight	1.4lbs
Standard	ISO22883

Advantages at a glance

Rolling Resistance	● ● ● ● ●
Operating Noise	● ● ● ○ ○
Floor Surface Preservation	● ● ● ○ ○

Dimensions

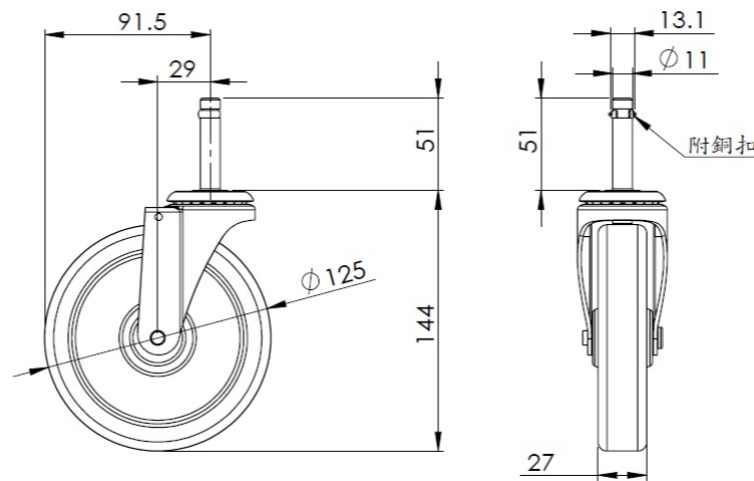

Mounting

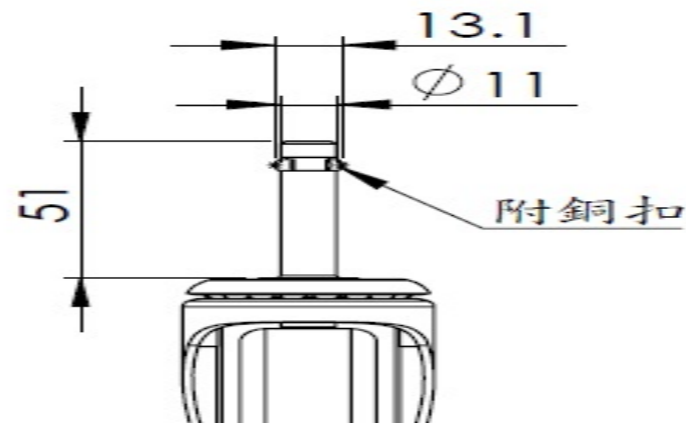

* For any deviation between metric and imperial spec, please refer to the metric spec.