

# 1116-SS-MI Medium Duty Institutional Stainless Steel Caster Series



Nylon Wheel Diameter × Wheel Width 75 x 31mm

EAN

TW-4111603004080

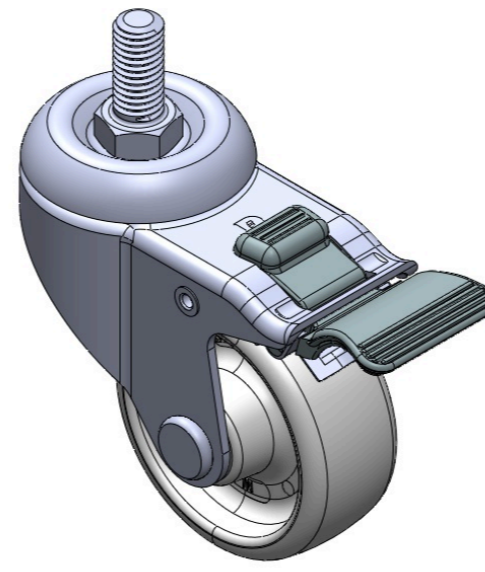

Drawings are for reference only and may differ from the product

Picture may differ from original product

## Technical Data

Metric  Imperial

Wheel Diameter	75mm
Wheel Width	31mm
Wheel Bearing	Wheel With Plain Bearing
Threaded Stem	1/2" -12牙
Threaded Length	28mm
Offset	41.5mm
Swivel Interference	212mm
Overall Height	107mm
Swivel Radius	106mm
Hardness Of Tread	75±5° Shore D
Load Capacity (Dynamic)	100kgs
Load Capacity (Static)	150kgs
Temperature	-20°C to +80°C
Fork Type	Swivel Caster With Total Brake
Stainless	Y
Electrical Conductivity	N/A
Anti-Static	N/A
Weight	0.65kgs
Standard	ISO22883

## Advantages at a glance

Rolling Resistance	● ● ● ● ●
Operating Noise	● ● ● ● ●
Floor Surface Preservation	● ● ● ● ●

## Dimensions

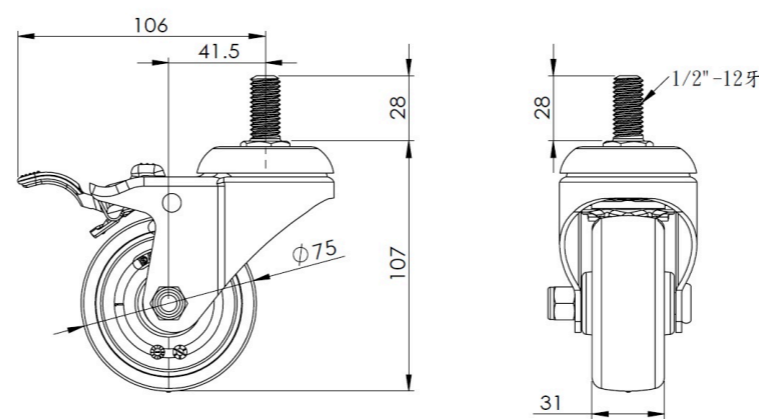

## Mounting

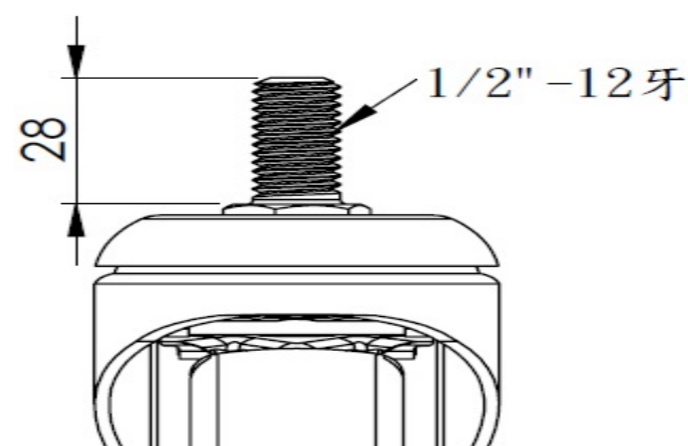

\* For any deviation between metric and imperial spec, please refer to the metric spec.