

# 1116-SS-MI Medium Duty Institutional Stainless Steel Caster Series



PPR Wheel Diameter × Wheel Width 100 x 31mm

EAN

TW-4111604004023

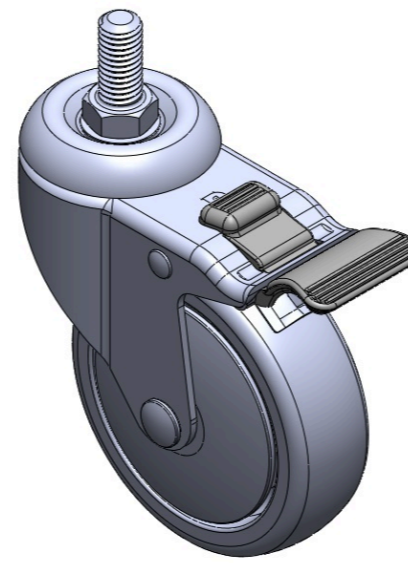

Drawings are for reference only and may differ from the product

Picture may differ from original product

## Technical Data

Metric  Imperial

Wheel Diameter	100mm
Wheel Width	31mm
Wheel Bearing	Wheel With Plain Bearing
Threaded Stem	1/2" -12
Threaded Length	28mm
Offset	41mm
Swivel Interference	210mm
Overall Height	134mm
Swivel Radius	105mm
Hardness Of Tread	82±5° Shore A
Load Capacity (Dynamic)	100kgs
Load Capacity (Static)	150kgs
Temperature	-20°C to +60°C
Fork Type	Swivel Caster With Total Brake
Stainless	Y
Electrical Conductivity	N/A
Anti-Static	N/A
Weight	0.75kgs
Standard	ISO22883

## Advantages at a glance

Rolling Resistance	●●●●○
Operating Noise	●●●●○
Floor Surface Preservation	●●●●●

## Dimensions

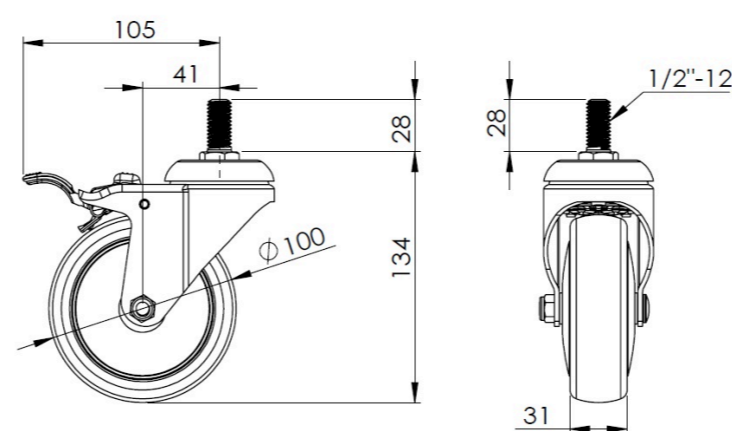

## Mounting

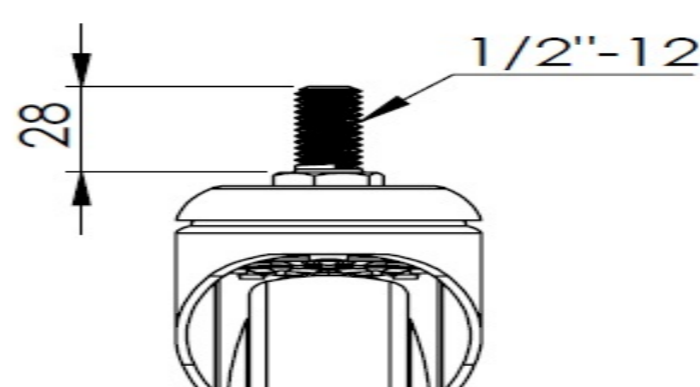

\* For any deviation between metric and imperial spec, please refer to the metric spec.