

# 1116-SS-MI Medium Duty Institutional Stainless Steel Caster Series



PPR E-conductive Wheel Diameter × Wheel Width 125 x 31mm

EAN

TW-4111605002068

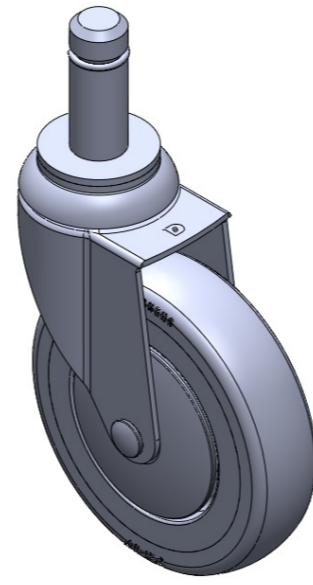

Drawings are for reference only and may differ from the product

Picture may differ from original product

## Technical Data

Imperial  Metric

Wheel Diameter	5 "
Wheel Width	1-1/4 "
Wheel Bearing	Wheels With Ball Bearings
Stem Diameter	7/8 "
Stem Length	2-1/4 "
Offset	1-9/16 "
Swivel Interference	8 "
Overall Height	6-1/2 "
Swivel Radius	4 "
Hardness Of Tread	82±5° Shore A
Load Capacity (Dynamic)	243lbs
Load Capacity (Static)	364lbs
Temperature	-4°F to +140°F
Fork Type	Swivel Caster
Stainless	Y
Electrical Conductivity	Y 導電值10 <sup>4</sup> ~10 <sup>6</sup>
Anti-Static	N/A
Weight	1.9lbs
Standard	ISO22883

## Advantages at a glance

Rolling Resistance	● ● ● ● ○
Operating Noise	● ● ● ● ○
Floor Surface Preservation	● ● ● ● ●

## Dimensions

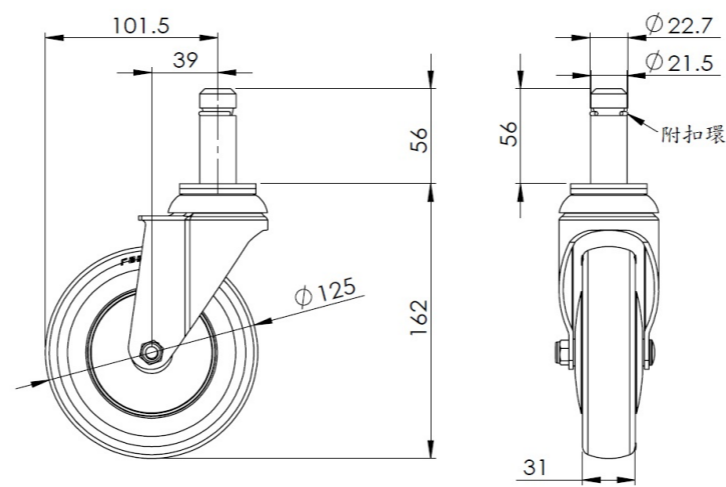

## Mounting

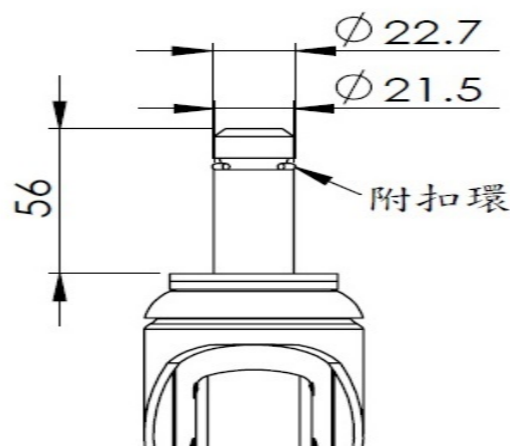

\* For any deviation between metric and imperial spec, please refer to the metric spec.