

1116-SS-MI Medium Duty Institutional Stainless Steel Caster Series



PPR (S) Wheel Diameter × Wheel Width 125 x 31mm

EAN

TW-4111605002073

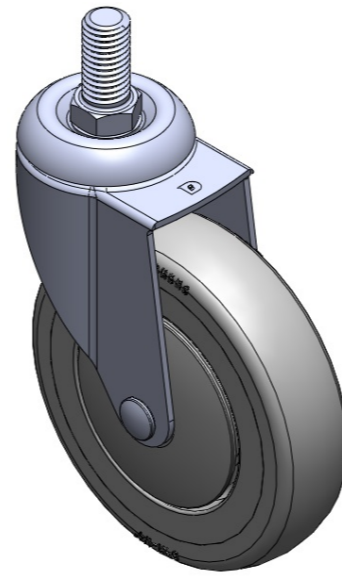

Drawings are for reference only and may differ from the product

Picture may differ from original product

Technical Data

Metric Imperial

Wheel Diameter	125mm
Wheel Width	31mm
Wheel Bearing	Wheels With Ball Bearings
Threaded Stem	5/8" -11
Threaded Length	32mm
Offset	39mm
Swivel Interference	203mm
Overall Height	164mm
Swivel Radius	101.5mm
Hardness Of Tread	82±5° Shore A
Load Capacity (Dynamic)	110kgs
Load Capacity (Static)	165kgs
Temperature	-20°C to +60°C
Fork Type	Swivel Caster
Stainless	Y
Electrical Conductivity	N/A
Anti-Static	N/A
Weight	0.75kgs
Standard	ISO22883

Advantages at a glance

Rolling Resistance	● ● ● ● ○
Operating Noise	● ● ● ● ○
Floor Surface Preservation	● ● ● ● ●

Dimensions

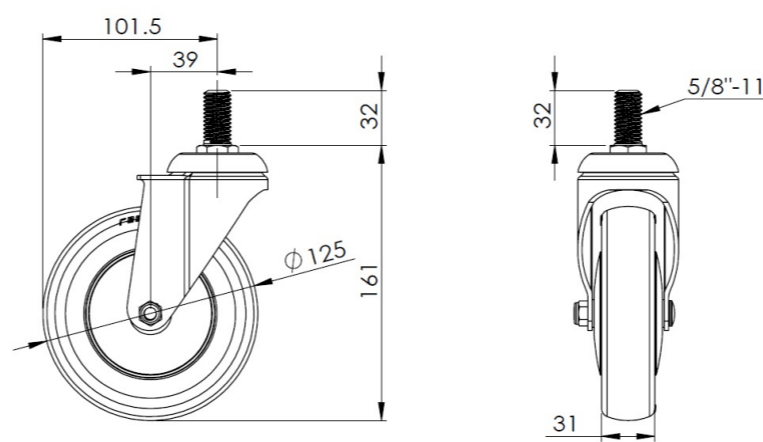

Mounting

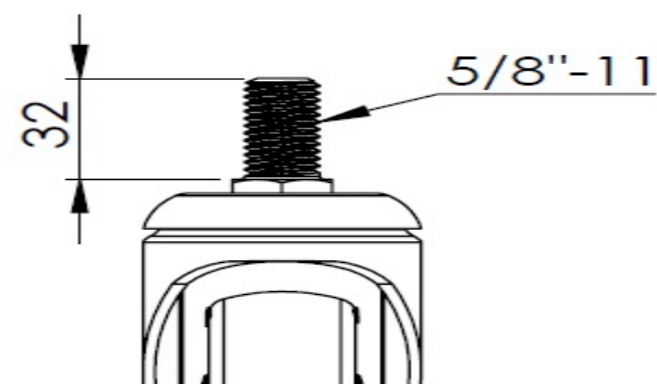

* For any deviation between metric and imperial spec, please refer to the metric spec.