

1121 Double Raceway, Light Duty Caster Series



Rubber wheel Wheel diameter × Wheel width 65×21 mm

EAN

YJ-11210250065014

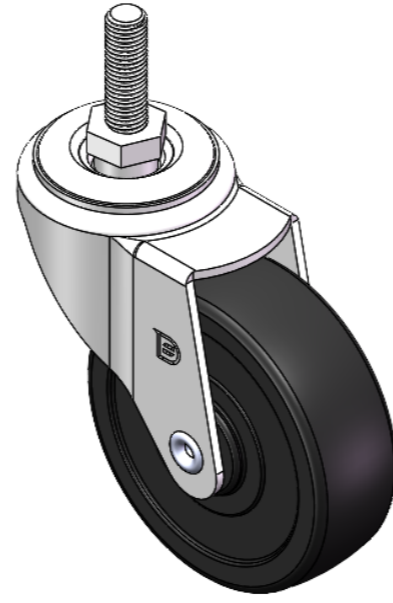

Drawings are for reference only and may differ from the product

Picture may differ from original product

Technical Data

Metric Imperial

Wheel Diameter	65mm
Wheel Width	21mm
Wheel Bearing	Wheel With Plain Bearing
Threaded Stem	5/16-18牙
Threaded Length	25mm
Offset	31mm
Swivel Interference	63.5mm
Overall Height	86mm
Hardness Of Tread	80±5° Shore A
Load Capacity (Dynamic)	40kgs
Load Capacity (Static)	60kgs
Temperature	-20°C to +120°C
Fork Type	Swivel Caster
Stainless	N/A
Electrical Conductivity	N/A
Anti-Static	N/A
Weight	0.29kgs
Standard	ISO22883

Advantages at a glance

Rolling Resistance	● ● ● ○ ○
Operating Noise	● ● ● ● ○
Floor Surface Preservation	● ● ● ● ○

Dimensions

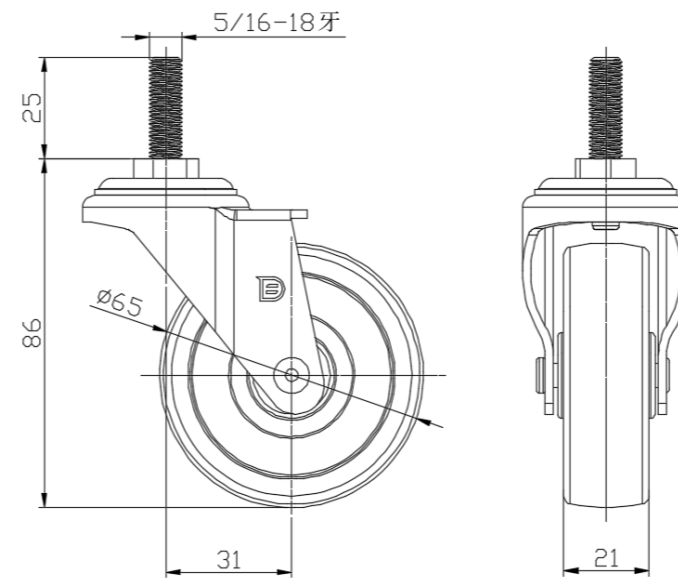

Mounting

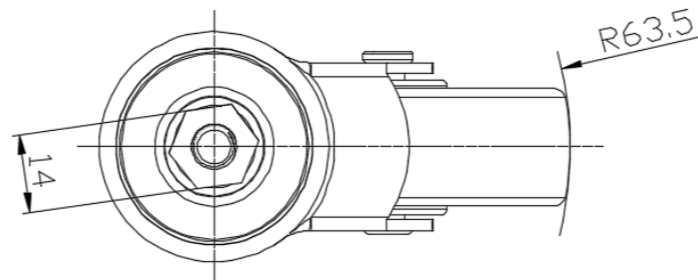

* For any deviation between metric and imperial spec, please refer to the metric spec.