

# 1121 Double Raceway, Light Duty Caster Series



Rubber wheel Wheel diameter × Wheel width 65×21 mm

EAN

YJ-11210250066013

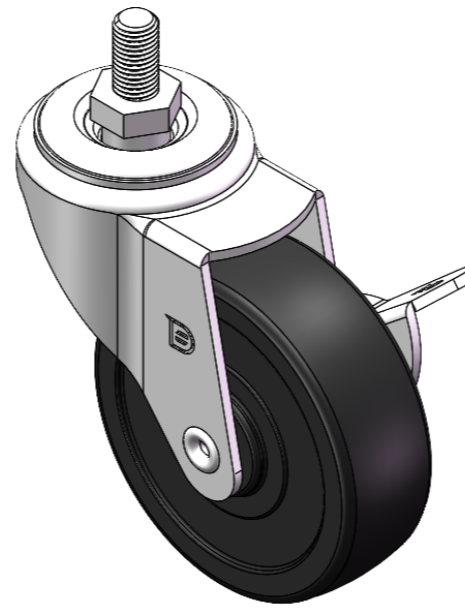

Drawings are for reference only and may differ from the product

Picture may differ from original product

## Technical Data

Imperial  Metric

Wheel Diameter	2-9/16
Wheel Width	7/8 "
Wheel Bearing	Wheel With Plain Bearing
Threaded Stem	M8-P1.25
Threaded Length	5/8 "
Offset	1-1/4 "
Swivel Interference	5 "
Overall Height	3-7/16 "
Swivel Radius	2-1/2 "
Hardness Of Tread	80±5° Shore A
Load Capacity (Dynamic)	88lbs
Load Capacity (Static)	132lbs
Temperature	-4°F to +248°F
Fork Type	Swivel Caster With Side Brake
Stainless	N/A
Electrical Conductivity	N/A
Anti-Static	N/A
Weight	0.6lbs
Standard	ISO22883

## Advantages at a glance

Rolling Resistance	● ● ● ○ ○
Operating Noise	● ● ● ● ○
Floor Surface Preservation	● ● ● ● ○

## Dimensions

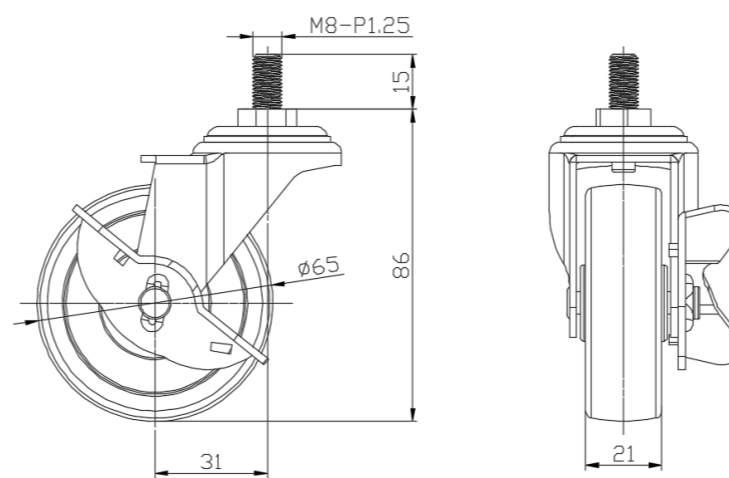

## Mounting

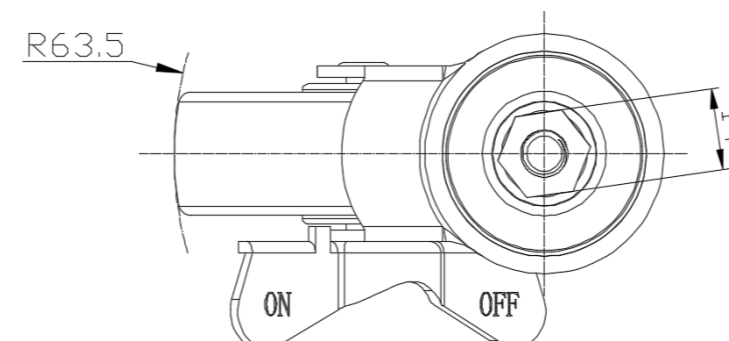

\* For any deviation between metric and imperial spec, please refer to the metric spec.