

# 1121 Double Raceway, Light Duty Caster Series



MRC Wheel (black) Wheel diameter × Wheel width 65×23.5 mm

EAN

YJ-11210250076023

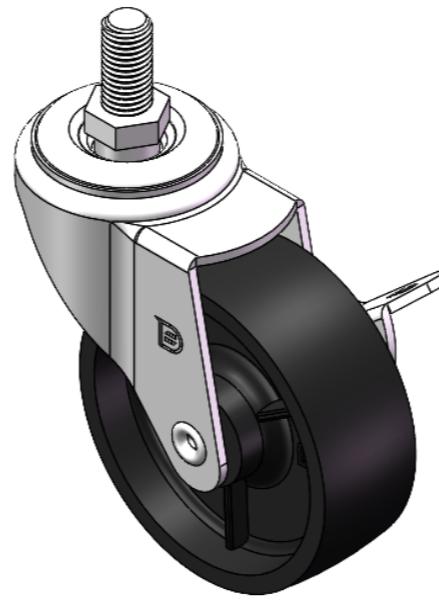

Drawings are for reference only and may differ from the product

Picture may differ from original product

## Technical Data

Metric  Imperial

Wheel Diameter	65mm
Wheel Width	23.5mm
Wheel Bearing	Wheel With Plain Bearing
Threaded Stem	5/16-18牙
Threaded Length	19mm
Offset	31mm
Swivel Interference	102mm
Overall Height	86mm
Swivel Radius	63.5mm
Hardness Of Tread	75±5° Shore D
Load Capacity (Dynamic)	35kgs
Load Capacity (Static)	52.5kgs
Temperature	-20°C to +80°C
Fork Type	Swivel Caster With Side Brake
Stainless	N/A
Electrical Conductivity	N/A
Anti-Static	N/A
Weight	0.19kgs
Standard	ISO22883

## Advantages at a glance

Rolling Resistance	● ● ● ● ●
Operating Noise	● ● ● ● ●
Floor Surface Preservation	● ● ● ● ●

## Dimensions

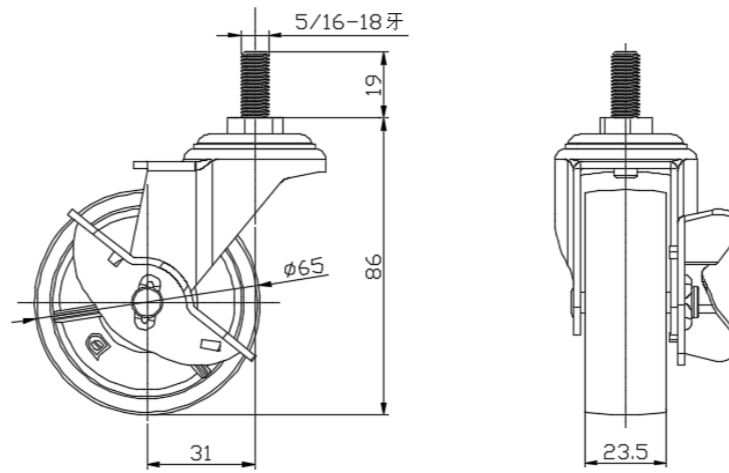

## Mounting

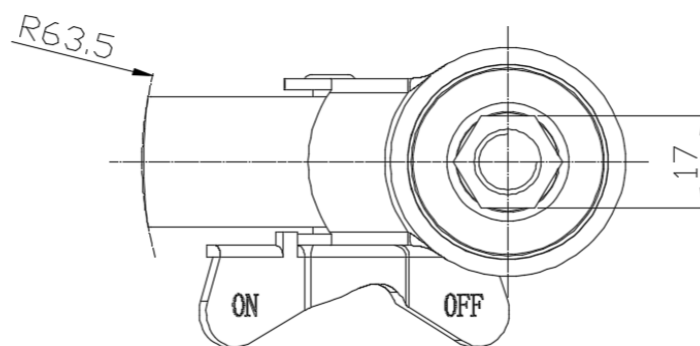

\* For any deviation between metric and imperial spec, please refer to the metric spec.