

# 1121 Double Raceway, Light Duty Caster Series



Rubber wheel (black) Wheel diameter × Wheel width 75×21.5 mm

EAN

YJ-11210300061013

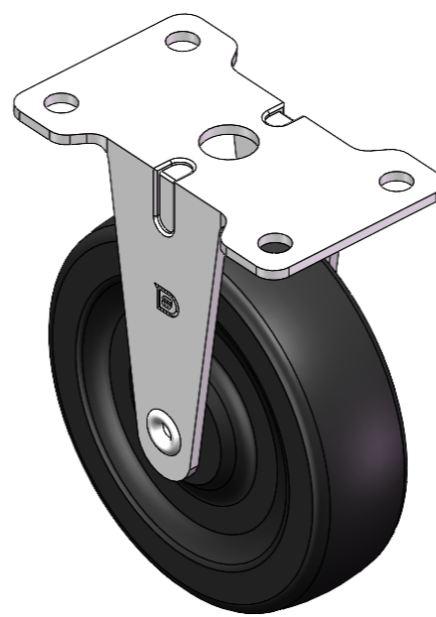

Drawings are for reference only and may differ from the product

Picture may differ from original product

## Technical Data

Imperial  Metric

Wheel Diameter	3 "
Wheel Width	7/8 "
Wheel Bearing	Wheel With Plain Bearing
Plate Size	2-13/16 " x 1-11/16 "
Bolt Hole Spacing	2-1/4 " x 1-1/8 "
Plate Hole	1/4 "
Overall Height	3-7/16 "
Hardness Of Tread	80±5° Shore A
Load Capacity (Dynamic)	110lbs
Load Capacity (Static)	165lbs
Temperature	-4°F to +248°F
Fork Type	Rigid Caster
Stainless	N/A
Electrical Conductivity	N/A
Anti-Static	N/A
Weight	0.5lbs
Standard	ISO22883

## Advantages at a glance

Rolling Resistance	● ● ● ○ ○
Operating Noise	● ● ● ● ○
Floor Surface Preservation	● ● ● ● ○

## Dimensions

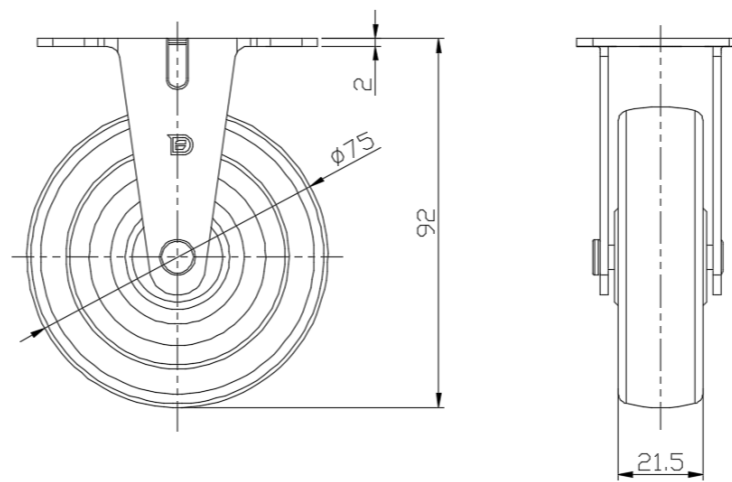

## Mounting

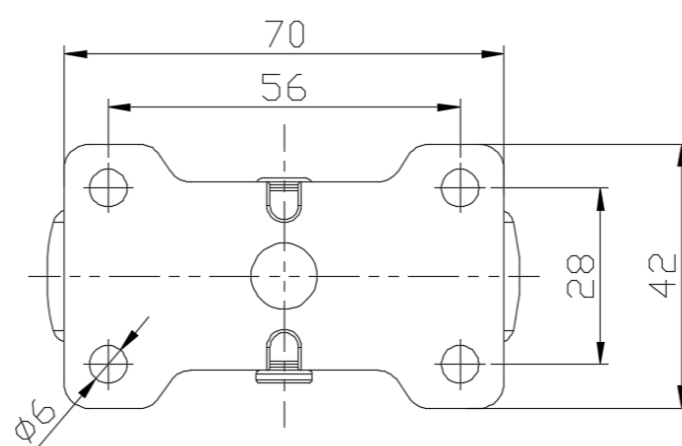

\* For any deviation between metric and imperial spec, please refer to the metric spec.