

# 1121 Double Raceway, Light Duty Caster Series



Rubber wheel (black) Wheel diameter × Wheel width 75×21.5 mm

EAN

YJ-11210300065043

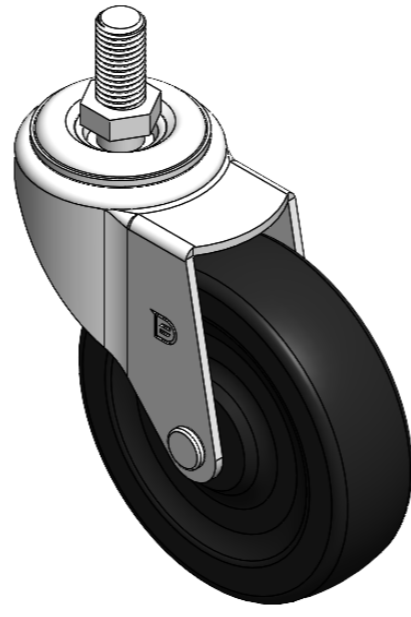

Drawings are for reference only and may differ from the product

Picture may differ from original product

## Technical Data

Metric  Imperial

Wheel Diameter	75mm
Wheel Width	21.5mm
Wheel Bearing	Wheel With Plain Bearing
Threaded Stem	M10-P1.5
Threaded Length	19mm
Offset	34mm
Swivel Interference	143mm
Overall Height	96mm
Swivel Radius	71.5mm
Hardness Of Tread	80±5° Shore A
Load Capacity (Dynamic)	50kgs
Load Capacity (Static)	75kgs
Temperature	-20°C to +120°C
Fork Type	Swivel Caster
Stainless	N/A
Electrical Conductivity	N/A
Anti-Static	N/A
Weight	0.28kgs
Standard	ISO22883

## Advantages at a glance

Rolling Resistance ●●●○○

Operating Noise ●●●●○

Floor Surface Preservation ●●●●○

## Dimensions

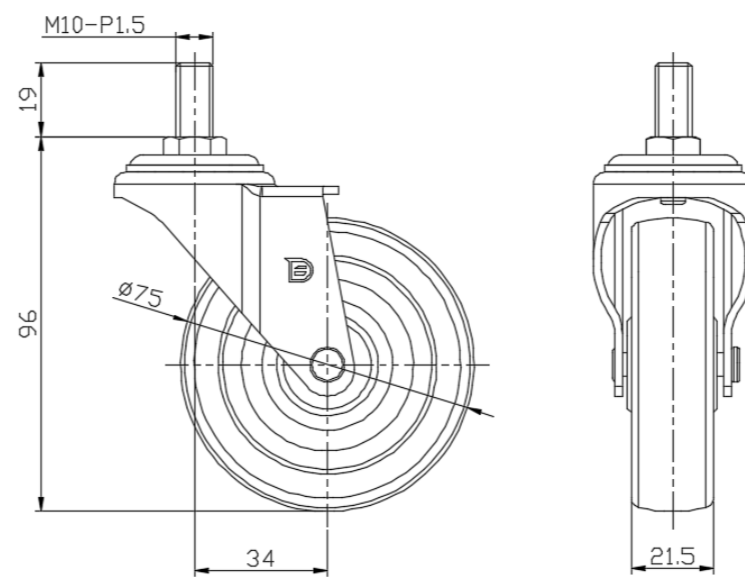

## Mounting

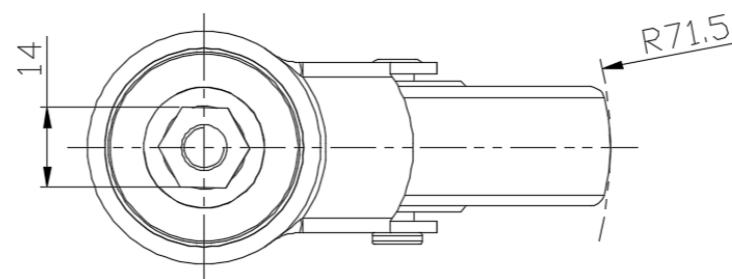

\* For any deviation between metric and imperial spec, please refer to the metric spec.