

1121 Double Raceway, Light Duty Caster Series



Rubber wheel (black) Wheel diameter × Wheel width 75×21.5 mm

EAN

YJ-11210300065063

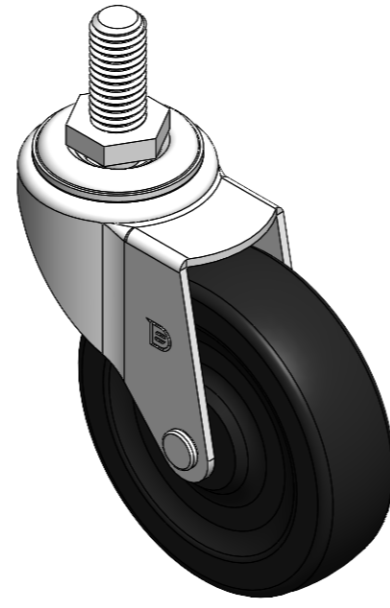

Drawings are for reference only and may differ from the product

Picture may differ from original product

Technical Data

Metric Imperial

Wheel Diameter	75mm
Wheel Width	21.5mm
Wheel Bearing	Wheel With Plain Bearing
Threaded Stem	M12-P1.75
Threaded Length	25mm
Offset	34mm
Swivel Interference	143mm
Overall Height	96mm
Swivel Radius	71.5mm
Hardness Of Tread	80±5° Shore A
Load Capacity (Dynamic)	50kgs
Load Capacity (Static)	75kgs
Temperature	-20°C to +120°C
Fork Type	Swivel Caster
Stainless	N/A
Electrical Conductivity	N/A
Anti-Static	N/A
Weight	0.29kgs
Standard	ISO22883

Advantages at a glance

Rolling Resistance ●●●○○

Operating Noise ●●●●○

Floor Surface Preservation ●●●●○

Dimensions

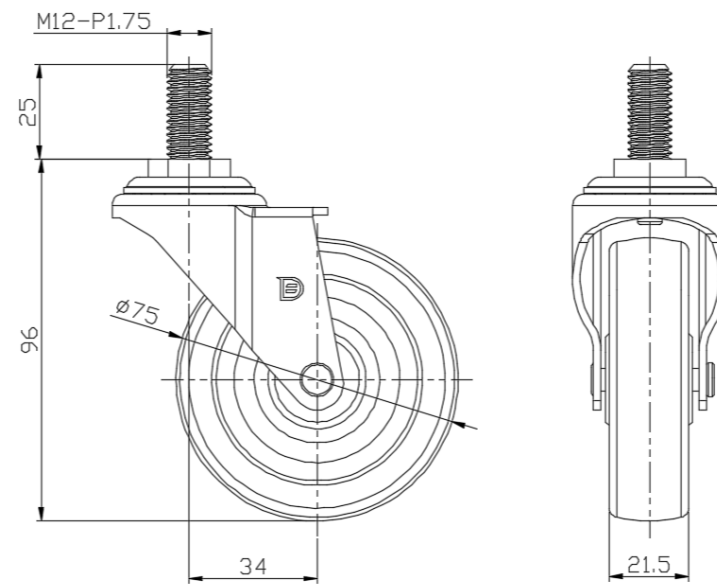

Mounting

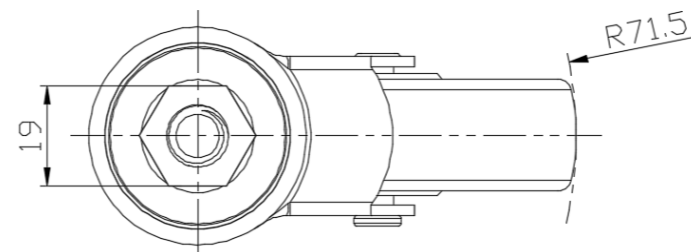

* For any deviation between metric and imperial spec, please refer to the metric spec.