

1121 Double Raceway, Light Duty Caster Series



Rubber wheel (black) Wheel diameter × Wheel width 75×21.5 mm

EAN

YJ-11210300065063

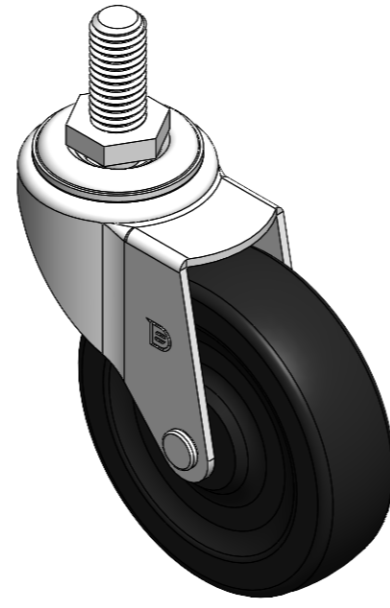

Drawings are for reference only and may differ from the product

Picture may differ from original product

Technical Data

Imperial Metric

Wheel Diameter	3 "
Wheel Width	7/8 "
Wheel Bearing	Wheel With Plain Bearing
Threaded Stem	M12-P1.75
Threaded Length	1 "
Offset	1-1/4 "
Swivel Interference	5 "
Overall Height	3-7/16 "
Swivel Radius	2-7/8 "
Hardness Of Tread	80±5° Shore A
Load Capacity (Dynamic)	110lbs
Load Capacity (Static)	165lbs
Temperature	-4°F to +248°F
Fork Type	Swivel Caster
Stainless	N/A
Electrical Conductivity	N/A
Anti-Static	N/A
Weight	0.6lbs
Standard	ISO22883

Advantages at a glance

Rolling Resistance	● ● ● ○ ○
Operating Noise	● ● ● ● ○
Floor Surface Preservation	● ● ● ● ○

Dimensions

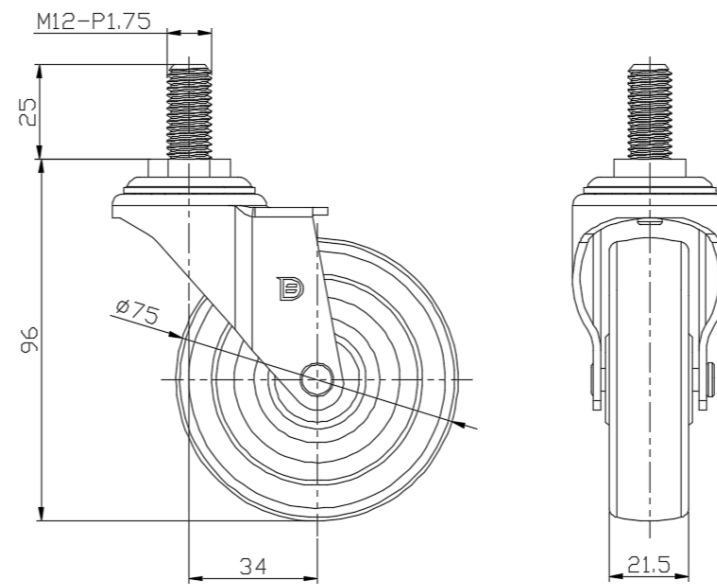

Mounting

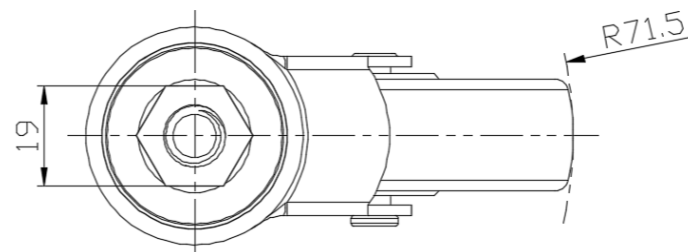

* For any deviation between metric and imperial spec, please refer to the metric spec.