

HPU Series

Wheel Diameter × Wheel Width 200 x 42mm

EAN

YJ-12039608180100

Excellent Mechanical Properties and wear resistance
 Excellent resistance to chemicals and corrosion
 Suitable for Forklift Trucks, Electric Stackers, AGVs, and floor scrubbers
 HPU, black, surface machined with random textured E
 Increases grip on the ground, effectively improving anti-slip ability

Wheel Center: Aluminum core
 Wheel Tread: High-quality polyurethane



Picture may differ from original product

Product descriptions are for reference only. The actual product shall prevail.

Technical Data

Metric Imperial

Wheel Diameter (D)	200mm
Wheel Width (T2)	42mm
Wheel installation — Hub Lenth (T1)	40mm
Wheel center-bore diameter (d)	115mm
Wheel Mounting Bolt Hole PCD Diameter	11.5mm
Wheel Mounting Bolt Hole PCD	133mm
# Of Wheel mounting bolt boles	6
Wheel mounting bolt hole (M)	8
Number of wheel mounting bolt holes	6
Load Capacity (Static)	900kgs
Load Capacity at 4 km/h	600kgs
Load Capacity at 6 km/h	510kgs
Load Capacity at 10 km/h	420kgs
Load Capacity at 16 km/h	240kgs
Hardness Of Tread	92±5° Shore A
Temperature	-20°C to +70°C
Tread Pattern	garbled text E
Wheel centre/ rim	Aluminum core / black paint
Non-Marking	Y
Conductive	N/A 10 ⁶ /Ω ~10 ^{8.5} /Ω
Anti	N/A
Weight	1.70kgs
Standard	ISO22883

Advantages at a glance

Rolling Resistance	•••••
Operating Noise	•••••
Floor Surface Preservation	•••••

2D Dimensional Drawing of Drive Wheel

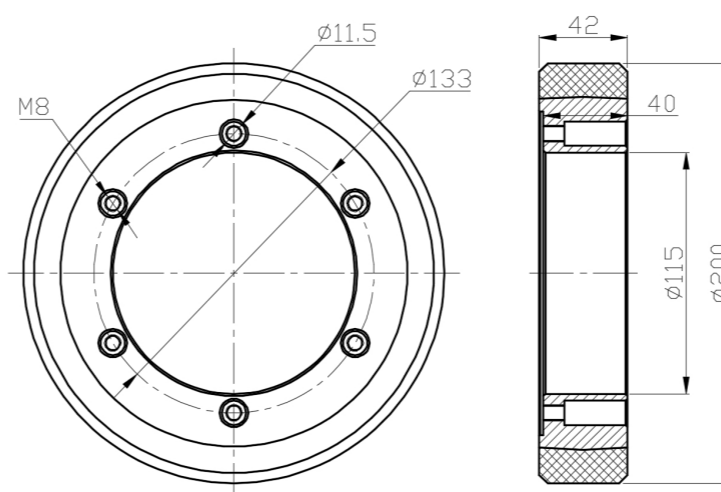

* For any deviation between metric and imperial spec, please refer to the metric spec.