

## HPU Series

Wheel Diameter × Wheel Width 200 x 42mm

EAN

YJ-12039608180100

Excellent Mechanical Properties and wear resistance  
 Excellent resistance to chemicals and corrosion  
 Suitable for Forklift Trucks, Electric Stackers, AGVs, and floor scrubbers  
 HPU, black, surface machined with random textured E  
 Increases grip on the ground, effectively improving anti-slip ability

Wheel Center: Aluminum core  
 Wheel Tread: High-quality polyurethane



Picture may differ from original product

Product descriptions are for reference only. The actual product shall prevail.

### Technical Data

<input checked="" type="radio"/> Imperial <input type="radio"/> Metric	
Wheel Diameter (D)	8 "
Wheel Width (T2)	1-11/16 "
Wheel installation — Hub Lenth (T1)	1-5/8 "
Wheel center-bore diameter (d)	4-9/16 "
Wheel Mounting Bolt Hole PCD Diameter	1/2 "
Wheel Mounting Bolt Hole PCD	5-1/2 "
# Of Wheel mounting bolt boles	6
Wheel mounting bolt hole (M)	8
Number of wheel mounting bolt holes	6
Load Capacity (Static)	1984lbs
Load Capacity at 4 km/h	1323lbs
Load Capacity at 6 km/h	1124lbs
Load Capacity at 10 km/h	926lbs
Load Capacity at 16 km/h	529lbs
Hardness Of Tread	92±5° Shore A
Temperature	-4°F to +158°F
Tread Pattern	garbled text E
Wheel centre/ rim	Aluminum core / black paint
Non-Marking	Y
Conductive	N/A 10 <sup>6</sup> Ω ~10 <sup>8.5</sup> Ω
Anti	N/A
Weight	3.7lbs
Standard	ISO22883

### Advantages at a glance

Rolling Resistance	•••••
Operating Noise	•••••
Floor Surface Preservation	•••••

### 2D Dimensional Drawing of Drive Wheel

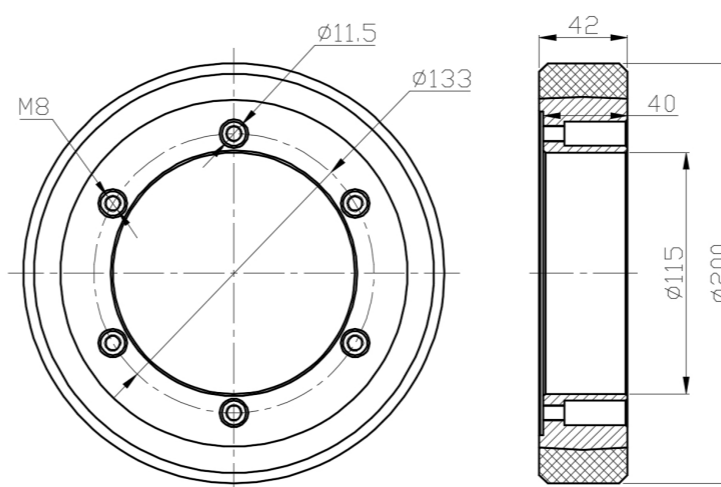

\* For any deviation between metric and imperial spec, please refer to the metric spec.